

a clear edge

RV oil-sealed rotary vane pumps



Vacuum science... product solution.

a clear edge

dedicated to science

Applications

You can be assured Edwards has the application expertise and the RV pump or integrated system solution to meet your needs

Mass spectrometry

GCMS, LCMS, ICPMS, MALDI, RGA, surface science, leak detectors

Electron microscopy

TEM, SEM, sample coaters

Sample preparation

Gel dryers, glove boxes, rotary evaporators, centrifuges

Research and development

Chamber evacuation, coating systems, turbopump backing

High energy physics

Beam lines, accelerators, mobile pump carts, turbopump backing, laser evacuation

Industrial

Glove boxes, coating systems, freeze drying, gas bottle filling/emptying, refrigeration system manufacture, degassing/curing (oil, epoxy resin)

Chemical

Gel dryers, glove boxes, rotary evaporators, centrifuges, distillation/ extraction/ filtration

RV oil-sealed rotary vane pumps

Edwards 30 years of experience in scientific applications affords us a deep understanding of research practices and the role that vacuum plays within them, enabling us to develop and support class-leading vacuum products that underpin our customers entire research process.

The RV series of small oil-sealed rotary vane pumps deliver excellent ultimate vacuum pressure, high pumping speeds and superior vapour handling capabilities with quiet operation. With over 200,000 units sold, these pumps offer proven performance that sets the industry standard for R&D and scientific pumping applications.

All RV pumps are approved to UL and CSA standards by an external test house and feature our unique mode selector switch, meaning one model is suitable for both high vacuum or high throughput applications. In summary, you can rest assured that when you choose an Edwards RV oil-sealed rotary vane pump you are choosing a product you can rely on from a company you can trust.



Features and benefits

Gas ballast

Two position gas ballast allows either 60g/hr or a class leading 220g/hr (290g/hr on RV12) of water vapour to be handled. This can be combined with an oil return accessory and an oil mist filter to enable continuous pumping with no loss of lubrication. Gas ballast can be automated by fitting the optional solenoid operated gas ballast valve.

Motor

Universal motor to cover the widest possible voltage and frequency range from a single motor. The single phase motor has an external switch change from high (220-240V) to low (110-120V) voltage range. A universal 3 phase motor is also available on all models and for special applications, pumps with flameproof ATEX approved motors can be offered.

Inlet

Best in class anti-suckback protection

- Smooth controlled opening by oil pressure to eliminate pressure surges
- Rapid closing within 0.4 seconds of pump stopping due to dump valve

All Edwards RV pumps are supplied with an inlet seal and integrated inlet mesh filter.

Oil

Edwards RV pumps are supplied with an initial charge of Ultragrade 19 oil. This premium quality has been specifically formulated with a unique package of additives to give the best vacuum performance of any mineral oil. As such it combines an extremely tightly controlled vapour pressure with a high resistance to oxidation for a long life. For oxygen rich applications PFPE prepared pumps are also available. Fomblin® must be purchased separately for PFPE prepared pumps.

Designed for easy maintenance

- Once size hex-head wrench to dismantle all parts
- All parts self-aligning so no jugs or special assemblies required
- Polymer blades with no springs or pins for easier assembly and greater reliability
- Shaft seals can be replaced for the motor side without dismantling the pump mechanism
- No O-rings between the slices for easier assembly
- All parts are interchangeable so can be ordered separately

Mode switch

The unique patented mode selector switch means that one pump fits all, so you only need one model for both high throughput and high vacuum applications.

In high throughput mode the selector switch increases the oil flow to the high vacuum stage allowing the pump to operate continuously with high inlet pressures without any wear or loss of lubrication.



Dimensions

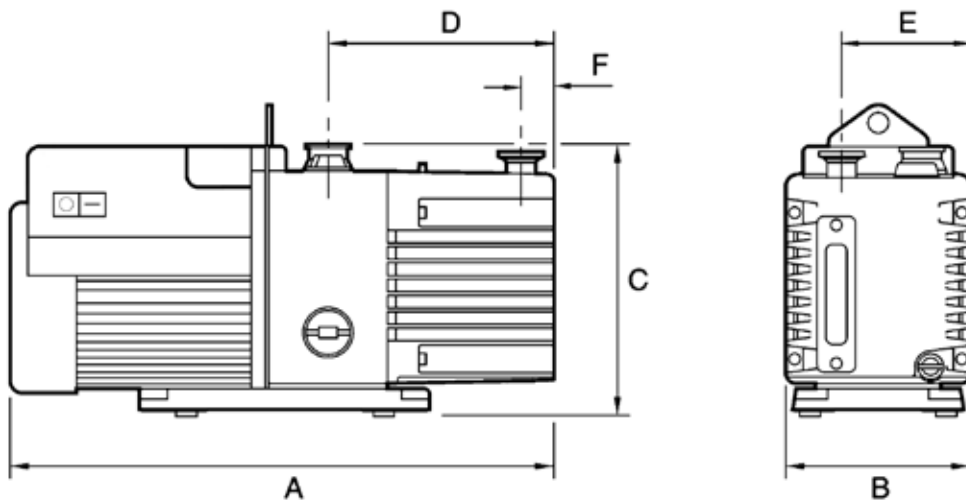

	A	B	C	D	E	F
RV3	430 (16.93)	158 (6.22)	225 (8.86)	156 (6.41)	111 (4.37)	29 (1.14)
RV5	430 (16.93)	158 (6.22)	225 (8.86)	156 (6.41)	111 (4.37)	29 (1.14)
RV8	470 (18.50)	158 (6.22)	225 (8.86)	196 (7.72)	111 (4.37)	35 (1.38)
RV12	490 (19.29)	158 (6.22)	225 (8.86)	216 (8.50)	111 (4.37)	35 (1.38)

Note: Single phase pump diagram shown, 3 phase pumps look different but share the same dimensions.

Dimensions shown in mm(inch).

Technical data

	Hz	Units	RV3	RV5	RV8	RV12
VACUUM DATA						
Peak pumping speed	60	cfm	2.3	3.6	5.9	8.4
	50	m ³ /h	3.3	5.1	8.5	12
Ultimate pressure (Total)	60	Torr	1.5 x 10 ⁻³			
			1.5 x 10 ⁻² with Fomblin®			
Ultimate pressure (Total)	50	mbar	2.0 x 10 ⁻³			
			2.0 x 10 ⁻² with Fomblin®			
Ultimate pressure GB I (Total)	50/60	Torr	2.3 x 10 ⁻²			
		mbar	3.0 x 10 ⁻²			
Ultimate pressure GB II (Total)	50/60	Torr	9.1 x 10 ⁻²	9.1 x 10 ⁻²	4.6 x 10 ⁻²	9.1 x 10 ⁻²
		mbar	1.2 x 10 ⁻¹	1.2 x 10 ⁻¹	6.0 x 10 ⁻²	1.2 x 10 ⁻¹
High throughput mode	50/60	Torr	2.3 x 10 ⁻²			
		mbar	3.0 x 10 ⁻²			
Water vapor tolerance		Torr	60	38	38	24
		mbar	80	50	60	32
Water vapor capacity - GB I		g/h	60			
Water vapor capacity - GB II		g/h	220	220	220	290
MOTOR DATA						
Motor rating 1 phase (nominal)	60	W	550			
	50	W	450			
Motor rating 3 phase	60	W	300	300	550	550
	50	W	250	250	450	450
Nominal rotation speed	60	rpm	1800			
	50	rpm	1500			
PHYSICAL DATA						
Weight		lb	55	55	61.6	63.8
		kg	25	25	28	29
Oil capacity		litres	0.7	0.7	0.75	1
Oil type (Ultragrade)			19			
Inlet flange			NW25			
Exhaust flange			NW25			
Noise level	50	dB(A)	48			
Noise level (with Acoustic Enclosure)*	50	dB(A)	41			
Operating temperature range		°C	12 to 40			

* approximate noise reduction of 7 dB(A)

Ordering information

Product description		Order No.	Order No.
		Ultragrade Oil	PFPE prepared*
RV3	115/230V, 50/60Hz set to 230V	A65201903	A65209903
	100/200V, 50/60Hz	A65201904	A65209904
	200-220/380-415V, 50Hz 200-230/460V, 60Hz, 3 phase	A65201905	A65209905
	115/230V, 50/60Hz set to 115V	A65201906	A65209906
RV5	115/230V, 50/60Hz set to 230V	A65301903	A65309903
	100/200V, 50/60Hz	A65301904	A65309904
	200-220/380-415V, 50Hz 200-230/460V, 60Hz, 3 phase	A65301905	A65309905
	115/230V, 50/60Hz set to 115V	A65301906	A65309906
RV8	115/230V, 50/60Hz set to 230V	A65401903	A65409903
	100/200V, 50/60Hz	A65401904	A65409904
	200-220/380-415V, 50Hz 200-230/460V, 60Hz, 3 phase	A65401905	A65409905
	115/230V, 50/60Hz set to 115V	A65401906	A65409906
RV12	115/230V, 50/60Hz set to 230V	A65501903	A65509903
	100/200V, 50/60Hz	A65501904	A65509904
	200-220/380-415V, 50Hz 200-230/460V, 60Hz, 3 phase	A65501905	A65509905
	115/230V, 50/60Hz set to 115V	A65501906	A65509906

*PFPE fluid not included

Product description		Order No.
Cord sets	UK, three pin plug	A50505000
	North European plug	A50506000
	North American plug	A50507000
	No plug	A50508000
Oil	Ultragrade 19, 1 liter bottle	H11025015
	Fomblin YVAC 06/6 1kg (532 ml)	H11301019
Inlet accessories	Foreline trap - FL20K	A13305000
Outlet accessories	Oil mist filter - EMF10	A46226000
	Oil mist filter - EMF20	A46229000
Oil return kits	Clean application (no gas ballast)	A50420000
	Adjustable gas ballast	A50523000
Vibration isolators		A24801404
Spares kits	Clean and overhaul kit	A65201131
Acoustic enclosure	Low volts 110-120V	A50635906
	High volts 200-240V	A50635903

Pumps fitted with ATEX approved motors are available, contact Edwards for details

Pumps are supplied with initial charge of Ultragrade oil



Global contacts

Belgium

Brussels +32 2 300 0730

Brazil

Sao Paulo +55 11 3952 5000

China

Shanghai (toll free) 400 111 9618

France

Paris +33 1 4121 1256

Germany

Munich 0800 000 1456

India

Pune +91 20 4075 2222

Israel

Qiryat Gat +972 8 681 0633

Italy

Milan +39 02 48 4471

Japan

Yachiyo +81 47 458 8831

Korea

Bundang +82 31 716 7070

Singapore

Singapore +65 6546 8408

Taiwan R.O.C.

Jhunan Town +886 3758 1000

United Kingdom

Crawley +44 1293 528844

UK (local rate) 08459 212223

United States

Niagara (toll free) 1 800 848 9800